

ESD Workstation Kit

INSTRUCTION SHEET

Kit Includes:

- 1x ESD Matting (600x1200mm) with 4x10mm stud in each corner
- 1x ESD Caution Sign 300mm x 150mm, GB
- 1x UK Earth Bonding Plug 3x10mm Stud
- 1x10mm Fabric Adjustable Wrist Strap Hypo Allergenic
- 1x10mm to 10mm Coiled Earth Lead
- 1x10mm to 10mm Straight Lead
- 1x Instruction Leaflet

Notes: Wristband must be checked regularly for continuity.

INSTRUCTIONS:

STEP 1. Affix signage within EPA.



STEP 2. Place mat on bench.

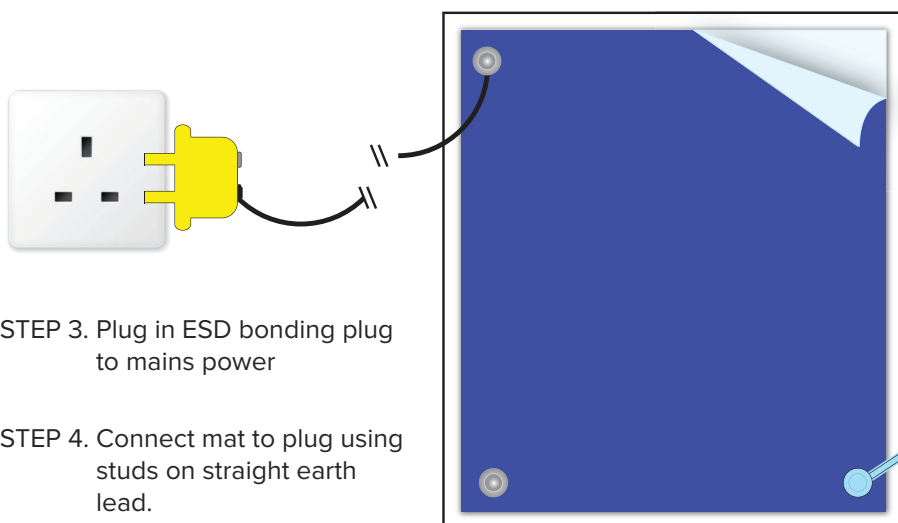

STEP 3. Plug in ESD bonding plug to mains power

STEP 4. Connect mat to plug using studs on straight earth lead.

STEP 5. Place wristband on wrist.

STEP 6. Connect wristband to stud on mat using coiled earth lead.

To request a quotation or for more information, please call **+44 (0)1473 836200**
email info@antistat.co.uk or visit www.antistat.co.uk

IMPORTANT: This data sheet and its contents (the "Information") belong to Antistat or are licensed to it. No licence is granted for the use of it other than for information purposes in connection with the products to which it relates. No licence of any intellectual property rights is granted. The information is subject to change without notice and replaces all data sheets previously supplied. The information supplied is believed to be accurate, but Antistat assumes no responsibility for its accuracy or completeness, any error in or omission from it or for any use made of it. Users of this data sheet should check for themselves the information and the suitability of the products for their purpose and not make any assumptions based on information included or omitted. Liability for loss or damage resulting from any reliance on the information or use of it (including liability resulting from negligence or where Antistat was aware of the possibility of such loss or damage arising) is excluded. © 2023 Antistat.